

Calculating Waves – not only on the Beach

Mechanical Calculation of Harmonic Waves by Harmonic Analysers

Dr. Detlef Zerfowski
(Kleinbottwar, Germany, email: Detlef@Zerfowski.com)

1 Harmonic Analysis – That sounds strange!

Have you ever heard the term "Harmonic Analysis"? Of course, it's not related to psychologists analysing the emotional binding between married couples. But it's a widely spread and extremely important methodology in science and engineering for analysing any kind of signal and data. The foundation of this methodology has been laid by the French mathematician and physicist Jean Baptiste Joseph Fourier (*21st March 1768, †16th May 1830) by publishing the "*Théorie analytique de la chaleur*" [Fou1822] (English translation "The Analytic Theory of Heat" [Fre1878]). Fourier's key observation can be summarized in the following way:

"Any periodic, continuous function can be generated by a series of sine and cosine functions."

or mathematically written the so-called Fourier series:

$$f(x) = \frac{a_0}{2} + \sum_{n=1}^N (a_n \cos(n \cdot w \cdot x) + b_n \sin(n \cdot w \cdot x))$$

Equation 1: Fourier Series.



Figure 1: Jean Baptiste Joseph Fourier
(Source: [Bou1823]).

For readers not so familiar with mathematics, this might look difficult to understand, but it's not so difficult at all. Let's assume, that you hear a sound, which is nothing else than perceived air waves $f(x)$ over time x . The Fourier series simply tells, that the sound wave $f(x)$ can be generated by

- harmonic waves $\sin(wx)$ and $\cos(wx)$ with the fundamental frequency w plus
- \cos and \sin waves with multiple frequencies nw of the fundamental frequency w and their amplitudes a_n and b_n .

With other words: The coefficients a_0, a_1, \dots, a_N and b_1, \dots, b_N completely describe the function $f(x)$. This series of amplitude coefficients are called the Fourier coefficients or Fourier transformation F of the function $f(x)$ (see Equation 1).

The process to determine the amplitude coefficients a_0, a_1, \dots, a_N and b_1, \dots, b_N for the harmonic \sin and \cos waves is called frequency analysis, Fourier analysis or harmonic analysis (see Figure 2). The opposite approach to generate the function $f(x)$ from harmonic waves is called Fourier synthesis. So the term harmonic analysis doesn't sound strange any more.

2 Applications of Harmonic Analysis and Fourier Transformation

The Harmonic Analysis and the corresponding Fourier transformation is a widely used tool in science and engineering. It's even visible in our daily live. Some of the readers of the article still might have a stereo sound system with an equalizer. The equalizer shows a set of amplitudes of frequencies of the recently played sound.

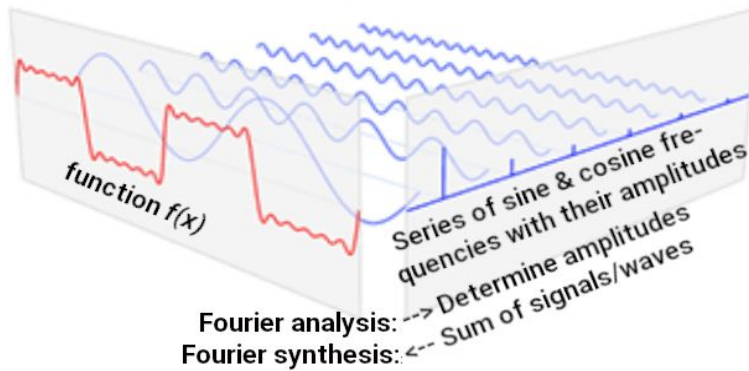

Figure 2: Visualization of Harmonic Analysis of a $f(x)$
 (Source: <https://de.wikipedia.org/wiki/Fourier-Analysis>)

Some of the readers might also know the smart phone app Shazam. This app "listens" for a short period of time to a song e.g. played in the radio. Within few seconds the app identifies the song and provides title, interpret and many more information of the song. The key algorithm in Shazam is the Fourier transformation, which gives a kind of fingerprint of the song. This fingerprint is immediately searched within a database

on a Shazam server containing millions of song fingerprints. As soon as the fingerprint is found the corresponding information of the song is provided.

Above mentioned applications are only two examples of the widely used Fourier transformation. There are many more cases, in the area of cryptography (e.g. for breaking ciphers to determine the period of used unknown cryptographic keys), medicine (e.g. the measured data in Magnetic Resonance Tomography are the Fourier transformation of the medical image), electrical engineering (including communication technology), etc. and for all these applications modern computers are used. Meanwhile you might ask, why this article is part of this book. The answer is, that there had been many applications of the methodology in the past as well. Around 1872/1873 William Thomson, later known as Lord Kelvin, invented a first tide computer (see Figure 3) followed by larger machines in 1876 and 1879 [Tho1881]. The periodic rotation of the moon around the earth, which turns around itself and around the sun have an influence on the height of the tide¹. Based on measured tide heights, harmonic components of this function had been derived, which then has been used for predicting the height of the tide for a period of up to two years for different places. Obviously this was of high relevance for ships approaching harbours.



Figure 3: Tidal machine (a harmonic synthesizer) by Thomson (Lord Kelvin) at the Science Museum London. Source: Wikipedia, published by William M. Connolley under Creative Commons License "Attribution-Share Alike 3.0".

An overview of existing harmonic analysers at the beginning of the 20th century has been given by Ernst Max Orlich. In his book on "Aufnahme und Analyse von Wechselstromkurven" (engl. "Recording and Analysis of Alternating Current Curves") [Orl1906] he described and compared analysers from Henrici and Coradi, Sharp,

¹We are getting closer to the beach! (According to the IM2019 theme "Calculators on the Beach".)

Yule and Le Conte, Wiechert and Sommerfeld, Michelson and Stratton, Terada. Many more references to harmonic analysers can also be found in [Zer2012].

3 Implementation of Mathematics into Mechanical Movements

Above mentioned tidal harmonic analysers obviously are one of a kind devices, specially built for one single purpose. As a consequence these devices have been extremely expensive and therefore have not been wide spread.

At the beginning of the 20th century there was an increasing demand for harmonic analyses for graphically given functions as well. In 1909 Otto Mader [Mad1909] mentioned application fields from applied mathematics, physics, mechanical engineering, shipbuilding² and electrical engineering.

In his article Mader described his newly invented "Simple Harmonic Analyser" and advertised for the same with following key features:

- Easy to understand and use (e.g. no side calculations are required).
- The instrument is ready to use for any kind of curve (i.e. function $f(x)$) without a need for redrawing or rescaling the curve upfront.
- The instrument is cheap.

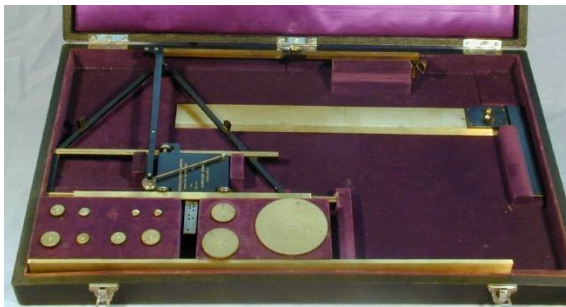

Figure 4: Harmonic analyser by Mader from collection [GitSie2004].

In 1909 the price for the Mader Harmonic Analyser was 120 Mark (sold by Stärzl Brothers at Vienna [Sta19??-3]), which in 2018 would be around 700 Euro (according to [Deu2019]).

Mader's analyser is based on already previously known approaches by Clifford (Finsterwalder [Fin1898]) and Yule [Yul1895]. Figure 4 shows a Mader harmonic analyser within its storage box. Figure 5 gives an idea how the device is set up ready for operation. In the same figure on the left, an elevated podium with an additional polar planimeter is shown, which in most cases is not part of the delivered harmonic analyser set itself. Due to the fact, that polar planimeters typically have been available with customers of harmonic analysers, the additionally required planimeter often was at least originally not part of the sold harmonic analyser set.

The following paragraphs describe how harmonic analysers are used to determine the coefficients a_0, a_1, \dots, a_N and b_1, \dots, b_N of the Fourier series. For the explanation we will focus on Mader-Ott analysers, which are improved and extended versions of the original Mader-Stärzl analyser.

Figure 6 shows a complete overview of all components required for the harmonic analysis. In this case, a planimeter (14) and the wooden podium (12) is part of the delivered set. A scanned version of the manual (17) is available in the internet (see [Ott1931-1], or the French version in [Ott1931-2]).

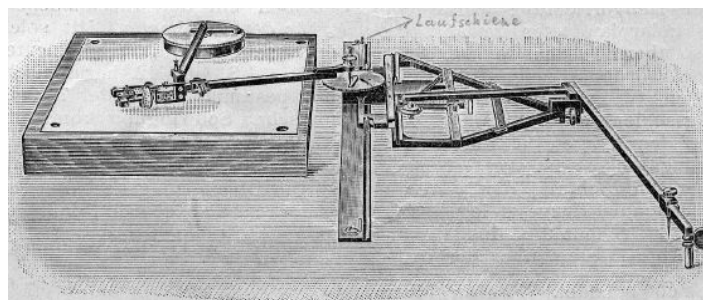

Figure 5: Harmonic analyser by Mader [Mad1909].

²Again an application close to the beach!

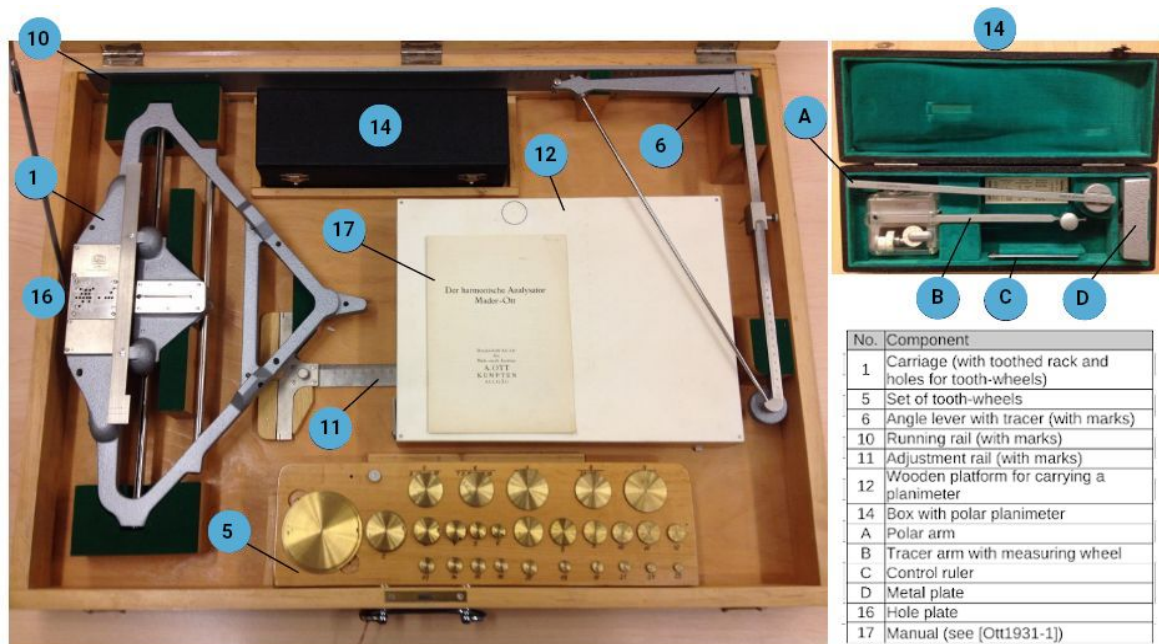

Figure 6: Complete box of a Mader-Ott harmonic analyser ([Gol2016] modified.)

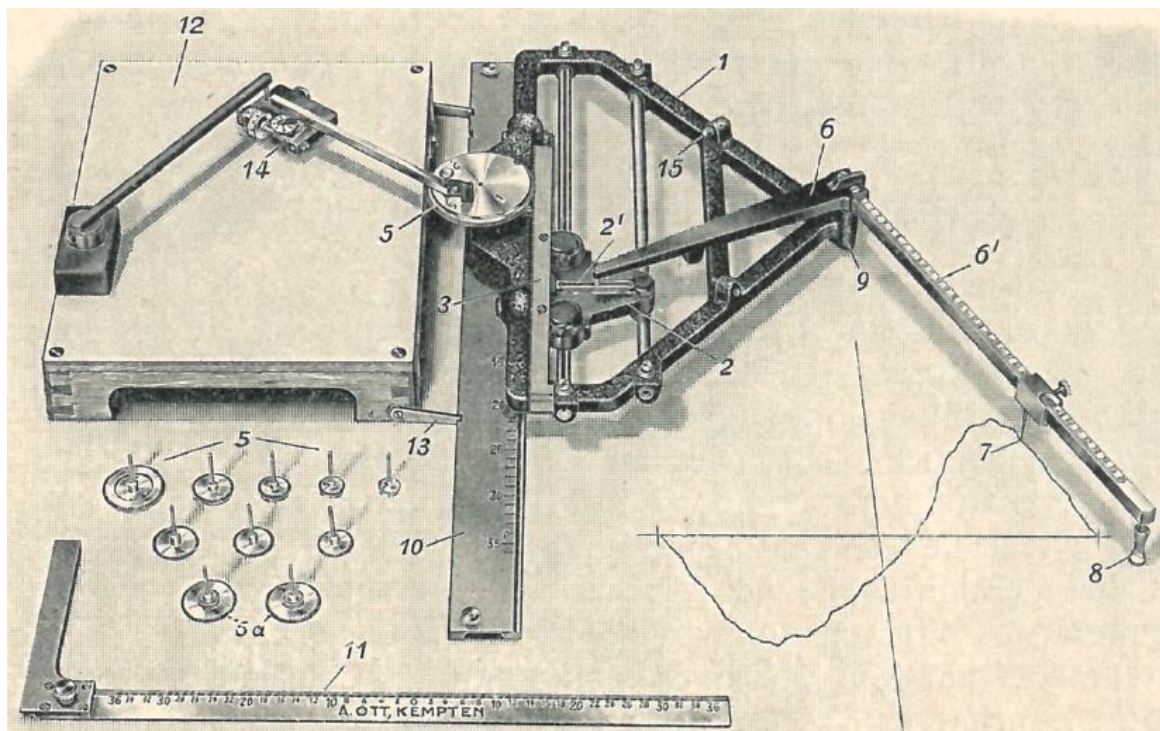

Figure 7: Setup of a Mader-Ott analyser [Ott1931-1].

3.1 Setting up the harmonic analyser

Before the harmonic analyser is used, it needs to be setup according to following procedure. (Numbers in brackets refer to Figure 6 and Figure 7.)

- The big carriage (1) is put onto the guiding rail of the metal ruler (10). So this carriage can move vertically up and down.

- The smaller carriage (2) is put into another rail within the big carriage (1). Therefore the smaller carriage (2) can move vertically within the big carriage (1). Be aware, that on the smaller carriage a toothed rail (3) is fixed (see also Figure 9). If the smaller carriage (2) moves up or down, the toothed rail (3) moves accordingly.
- The angle lever (6) is introduced into the horizontal guiding slit on the small carriage (2) and into a fixation hole (9) in the big carriage (1). Be aware that the arm of the angle lever (6) and the tracer arm (6') are fixed and form a right angle. The tracer arm (6') carries a tracer (7). This will later be moved over the function graph by using the handle (8).
- The angle lever can rotate in its fixation point (9). With this rotation the end of the arm (6) of the angle lever moves horizontally in the slit of the smaller carriage (2). This forces the smaller carriage (2) to move within the big carriage (1) up or down. With this movement the toothed rail (3) is forced to move up and down accordingly.
- From the set of numbered gear wheels (5) one brass wheel is taken. This wheel is put into the correspondingly numbered hole in the big carriage (1) (see also Figure 10). The numbered holes are located in such a manner that by placing the correct gear wheel, its teeth will fit into the toothed rail (3). So, if the small carriage (2), together with the toothed rail (3), moves up or down, the gear wheel (5) turns anti-clockwise or clockwise.
- Now we are looking at the left part of the analyser device. The wooden podium (12) is placed next to the setup. On top a polar planimeter (14) is placed.
Note: Any common polar planimeter can be used, which is the reason why planimeters often are not part of the harmonic analyser sets.
- Next, the planimeter needs to be connected to the rotating gear wheel. On each wheel two holes are available, marked with "S" and "C". The tracer of the polar planimeter (14) is put into one of this holes. If it's put into the hole marked "S", then the setup will provide a sine coefficient of the Fourier series (Equation 1), if it's located inside the "C" hole, a cosine coefficient is determined. (Figure 9 shows the "S" and "C" holes on a gear).
- Finally the adjustment rule (11) is used to align the function graph under the analyser in such a way, that the x -axis is orthogonal to the guiding rail (10) and that the entire graph can be reached by the tracer (7).
Note: The Mader-Ott analyser is able to analyse function graphs up-to 36 cm width and ± 16 cm height. With some mechanical tricks (folding the paper carrying the function graph), Nyström increased the maximum reachable height of the function graph to ± 48 cm [Nys1937].

3.2 Determine the Coefficient a_0 with a Planimeter

After setting up the harmonic analyser, the coefficients a_0, a_1, \dots, a_N and b_1, \dots, b_N of the Fourier series (Equation 1) can be determined.

The coefficient a_0 is the average height (i.e. the average value of the function $f(x)$ over the considered interval). Therefore a_0 can be determined with a planimeter only (the analyser is not required).

- The planimeter is placed next to function graph and the tracer is placed on the x -axis at the beginning of the interval of the function. The "starting value" is read from the planimeter.
- Now the tracer is guided over the function till the end of the interval. Afterwards the tracer is moved back along the x -axis towards the starting point. Again the planimeter reading (the "end value") is taken.

- The difference (end value) - (starting value) is the number of vernier units measured by the polar planimeter. So the coefficient a_0 is calculated by $a_0 = [(\text{end value}) - (\text{starting value})] * (\text{vernier unit of the planimeter})$

3.3 Determine Coefficients a_i and b_i with the Analyser

The following steps require the harmonic analyser. For the coefficients a_1 and b_1 the gear wheel numbered "1" is used. For a_2 and b_2 the wheel numbered "2" is used, and so forth. As already mentioned above, for the cosine coefficients a_i the tracer of the polar planimeter (14) needs to be located in the "C" hole of the gear wheels (5). For the sine coefficients b_i the "S" holes are used.

Now the measurement can start and the coefficient a_1 will be determined (gear wheel marked "1" is used and the tracer of the polar planimeter is located in the "C" hole).

- Move the tracer (7) of the angle lever to the starting point of the function $f(x)$.
- Read the starting value on the polar planimeter (14).
- Move the handle (8) such that the tracer (7) follows the curve $f(x)$.
- After the rightmost part of the curve has been reached, move the tracer (7) over the x -axis back to the starting point.
- Read the end value on the polar planimeter (14).
- The difference (end value) - (starting value) is the number of vernier units measured by the polar planimeter. So the coefficient a_1 is calculated by $a_1 = [(\text{end value}) - (\text{starting value})] * (\text{vernier unit of the planimeter})$

The other coefficients are determined in the same manner.

An interactive animation of operating an analyser can be found in [deM2019].

Above given instruction shows, that operating the harmonic analyser is possible without understanding the mechanical and mathematical theory. In the same manner [Boh1931] stated for using the Mader-Ott analyser in the domain of organbuilding: *"The ideal device for mechanically numerical determination of amplitude and phase of fundamental frequencies and overtones from periodic curves (e.g. from organ pipe oscillograms) and finding of hidden periodicities. For it's usage no above-average mathematical knowledge is required!"*

A similar statement can be found in [Wag1942] for the application in the field of meteorology.

For a deeper understanding of the mechanical theory of the analyser, readers should take a look at [Mad1909]. Even some decades after the invention of the analysers, scientists discussed and proved the accuracy of harmonic analysers (e.g. [Ack1928], [Bae1937-2]). Concerning the usage of planimeters and its own mechanical theory, a detailed description can be found in [HerZer2002].

4 Different Designs of Harmonic Analysers

In the previous sections the Fourier theory has been shown, the Mader-Ott harmonic analyser has been described and its operation has been explained. In this section, different variants of the Mader-Ott analyser will be looked at.



Figure 8: Mader-Ott analyser with two sets of 48 gears [Com2017-1].

4.1 Variance: Number of Gears

One cost driving factor of the analysers is the number of gear wheels provided with the analyser set. With more gear wheels, more coefficients could be determined and therefore more detailed analysis (towards higher frequencies) of the function $f(x)$ could be obtained. Of course the price of the device increases with the number of gears. According to my knowledge the Mader-Ott analyser with most gears is located at the Computer History Museum at Mountain View, California [Com2017-1]. It comes with two sets of 48 gears each, allowing a much more detailed analysis of functions $f(x)$ by getting coefficients for higher frequencies (Figure 8). With two complete gear sets and two hole plates on the carriage (see Section 4.2), the sine and cosine coefficients could be determined simultaneously with one trace of the graph $f(x)$. Typically the analyser sets are coming with gears to determine 6, 9, 19, 21, 23 or 25 frequencies.

Here we have to mention, that the number of gears with the analyser set is not always the same as the amount of frequencies (resp. coefficients) to be determined. Due to mechanical constraints some gear wheels cannot be placed in direct contact with the toothed rail (see (3) in Figure 7 and Figure 9). In this situation intermediate gear wheels are used. These intermediate gears consist of two toothed gears fixed above each other. The gear on top (Figure 9 upper right gear) drives the coefficient gear (gear numbered 8 in Figure 9). The lower gear (not visible beneath upper right gear) of the intermediate gear runs in the toothed rail (in Figure 9 the horizontal toothed rail on top).

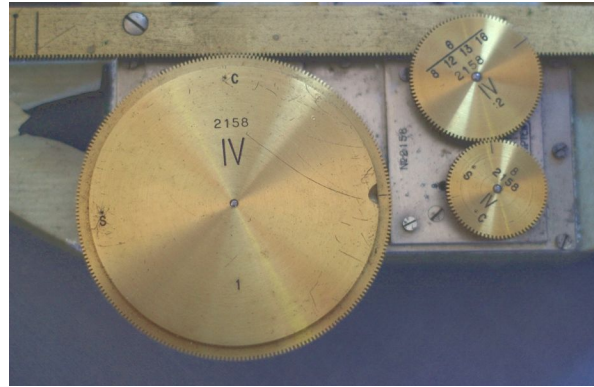

Figure 9: Gear wheels for coefficients a_1 and b_1 (left), as well as a_8 and b_8 (right). The upper right wheel is an intermediate gear. The toothed rail is the horizontal metal at the top.

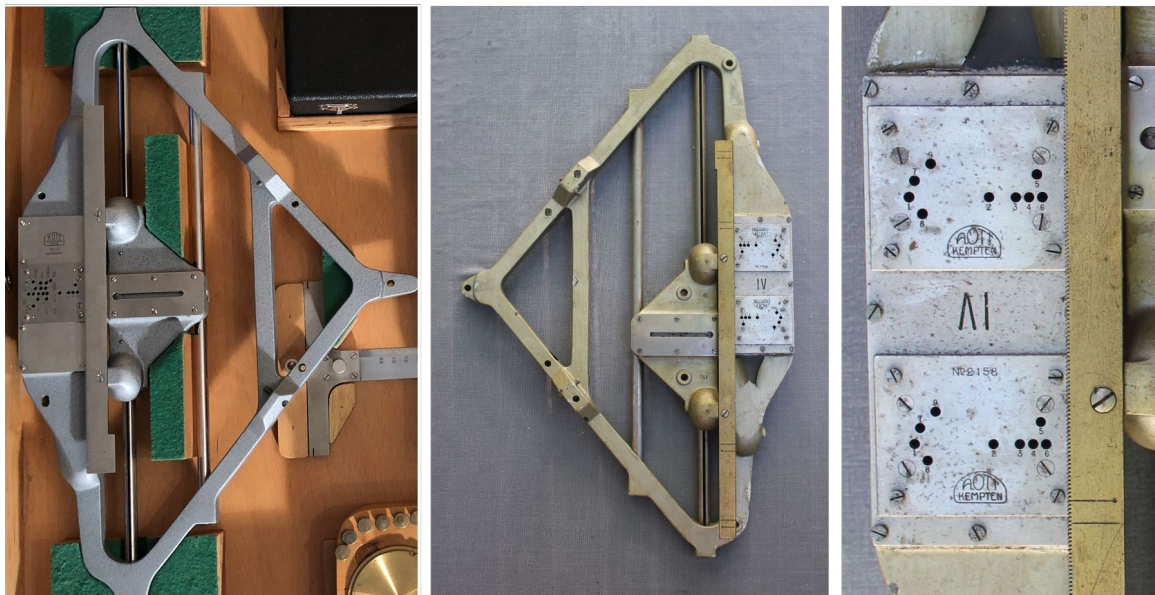

Figure 10: Carriages with one hole plate (left) and with double hole plate (center). Double hole plate (right) with numbered holes for carrying corresponding numbered gear wheels.

4.2 Variance: Number of Hole Plates

Till around 1941/1942 Mader-Ott analysers had been built with one hole plate on the analyser carriage (see Figure 10). According to [Mey1941] carriages with two hole plates on a single carriage had been introduced. The company Ott called analysers with two hole plates "Double Analysers". With this approach two planimeters could be operated with one single carriage in parallel. Using different gears with the two hole plates, two coefficients could be determined in a single operation while tracing the function $f(x)$ only once.

4.3 Variance: Number of Carriages

If a huge number of detailed Fourier analysis with many coefficients had been required, the operation of the harmonic analysers were quite time consuming. In these cases a higher level of parallelism was required. This has been achieved by mechanically connecting several carriages in a row, which is called a carriage train. Analyser trains with two or three carriages in one sequential row are known. A set with four carriages operated in parallel is shown in Figure 11. The fourth carriage is not put in the row with the other three carriages, but mounted to the second and

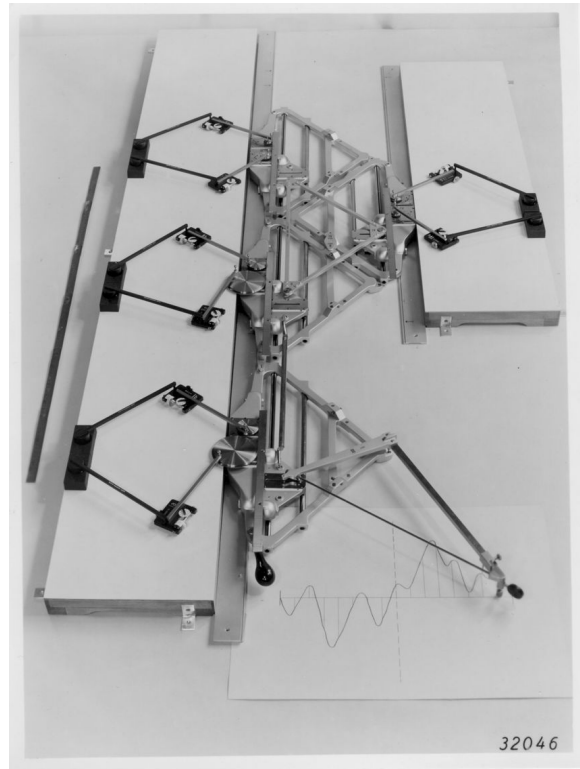

Figure 11: 8-fold harmonic analyser set-up for operation. Source: Photo by Ott, 3rd April 1941. Provided by Prof.

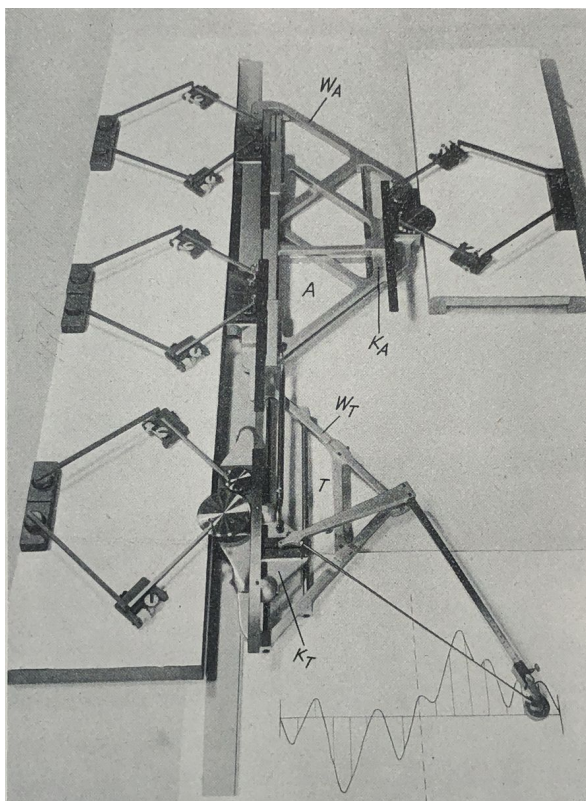

Figure 12: 8-fold Ott analyser [Wil1943], extendable towards a 14-fold analyser.

third carriage in a mirrored manner. Since each carriage is a double analyser, a total of eight planimeters could be operated simultaneously, delivering eight Fourier coefficients by one function trace. For this reason the device is named eight-fold analyser³. Obviously the time saving goes together with a higher space consumption. The entire setup in Figure 11 requires a table of 3.5 x 1.2 m. By the way: the storage box itself (Figure 13) has the size of about one square meter and weighs 45 kg, not including the additionally required 8 planimeters and the two large wooden supporting podiums for the planimeter.

³Also mentioned in [Wag1942] used in the domain of meteorology.



Figure 13: Storage box of Mader-Ott eight-fold harmonic analyser (Serial nos. 2155 to 2158, collection Zerfowski).

The largest known Ott analyser is based on above principle as well and is a 14-fold analyser. This analyser has been introduced around autumn 1942. In total fourteen (!) planimeters got connected to the entire setup and therefore 14 coefficients of the Fourier series could simultaneously be determined by one function trace. The 14-fold analyser is based on an improved version of the 8-fold analyser in Figure 11, where the upper three carriages are combined in one single mounted carriage (Figure 12) which holds six planimeters. This improved 8-fold analyser could be extended with another 6-fold carriage towards the upper end in Figure 12 leading to a 14-fold analyser. Since the improved version of the 8-fold analyser had been introduced into the market about one and a half year after the introduction of the 4-carriage version (Figure 11), only very few 4-carriage analysers might have been produced. Furthermore, it is confirmed, that the analyser in Figure 11 is the same analyser shown in Figure 13 with serial no. 2155 to 2158.

4.4 Variance: Additional Supplements

Another variance of Mader-Ott analysers are different supplements coming with the analyser sets. For example some storage boxes had been delivered together with a planimeter, some without any planimeter.

Especially single carriage analysers with single hole plates had been delivered with the wooden planimeter podium.

Due to the fact that common polar planimeters had been already widely spread, these devices



Figure 14: Mounted tracer arm extension (right).

might have been available with the customers and therefore could be used with the harmonic analysers. If required, additional planimeters could be bought separately. Another supplement addresses a significant constraint of the Mader-Ott analysers. Independent of the number of carriages typically function graphs with period width up-to 36 cm and ordinate height of ± 16 cm could be analysed. Together with a pantograph like extender, parallelly mounted to the analyser's tracer arm (see Figure 14) function graphs up-to 72 cm length could be analysed. This extension (named *Pireb*) has been sold separately ([Ott19??]) with a normal tracer or an attached 2-fold magnifying lens.

All analysers could be equipped with this magnifying lens, but this should have been considered during the initial order. Customer could not add the magnifying lens by themselves. In case an analyser should later be equipped with a lens, the analyser had to be send to the company Ott for modification.

Another extremely rare supplement is the extension of the Mader-Ott analyser with a so-called Stieltjes planimeter, which had been designed by Nyström [Nys1934, Nys1936]. Instead of the gear wheels and the inner carriage, the table-like add-on is mounted on top of the analyser's carriage (see Figure 15). The planimeter is connected to this movable Stieltjes supplement. While the harmonic analyser tracer is moved along the function, in Figure 15 the curve $y(t)$, a movement of the Stieltjes add-on is enforced. During this movement a second person needs to keep the lens of the Stieltjes device over a second curve $h(t')$, which is lying orthogonal (rotated) above $y(t)$ under the Stieltjes extension. With this approach the Mader-Ott analyser becomes a product planimeter providing the integral

$$\oint y(t) dh(t')$$

Equation 2: Stieltjes Integral

where $h(t')$ is a moment function which is a weight function within above integral. Even the support of a second person could be avoided, if the graph under the Stieltjes lens had been exchanged by a plate carrying the graph, where the Stieltjes tracer was mechanically forced to follow the curve $h(t')$ (see Figure 16 and [Mey1944, Wil1951]). A corresponding Stieltjes extension exists in the collection of the University of Stuttgart, Germany [Uni2018].

Of course, with a Stieltjes extension the device is not a harmonic analysis anymore.

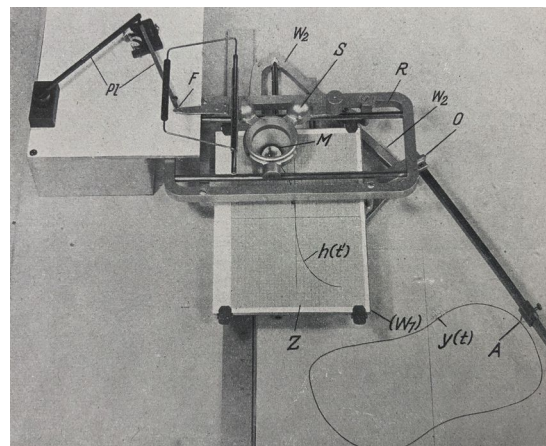

Figure 15: Stieltjes planimeter mounted on Mader-Ott harmonic analyser from [Mey1944].

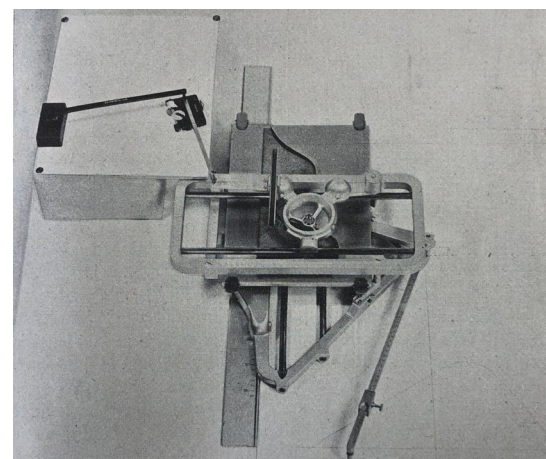

Figure 16: Stieltjes extension with enforced automatic movement along function $h(t')$ [Mey1944].

5 Stanley Harmonic Analysers

In this article analysers by Stärzl and Ott have been discussed. Here it should be mentioned, that during the 1950th till 1965 another company, W. F. Stanley & Co., Limited (London) manufactured Mader-like harmonic analysers as well (see Figure 17 and [Kir1950]).

According to [Sta19??-1, Sta19??-2] the company offered three variants, which differ in the following features:

- U8101, Stanley Harmonic Analyser No. 1: Single hole plate analyser including one planimeter and one set of gears for 1 to 6 sine and cosine coefficients. Cuves with base length of 4 to 40 cm and maximum ordinate of ± 20 cm could be analysed.
- U8102, Stanley Harmonic Analyser No. 2: Similar to U8101 but with double hole plate, two planimeters and two sets of gears.
- U8103, Stanley Harmonic Analyser No. 3: Similar to U8102 but with two sets of gears for 1 to 18 sine and cosine coefficients.

On customer request, Stanley supplied special combinations of harmonics in the range of 1 to 18.

In total about 55 to 60 analysers had been built by Stanley & Co., Limited (source: [Fis2019]). Table 1 shows the sales prices (without corresponding years) of the different analyser variants.



Figure 17: Stieltjes extension from the collection of the University of Stuttgart, Germany [Uni2018].

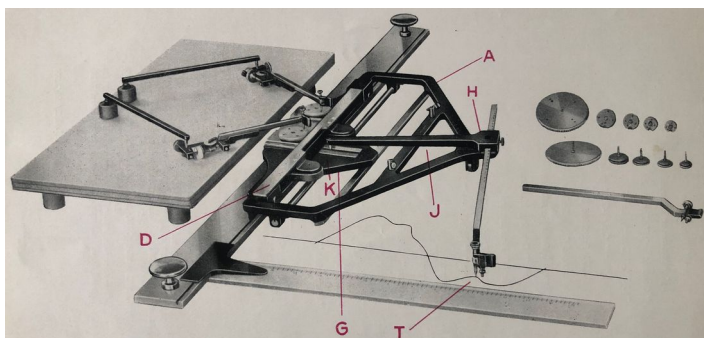

Figure 18: Stanley harmonic analyser [Sta19??-1].

Stanley Harmonic Analyser	Selling Price [Sta19??-1]	Selling Price [Sta19??-2]
U8101	£ 300	£ 108 Sh 18
U8102	£ 325	£ 145 Sh 4
U8103	£ 370	£ 242

Table 1: Selling prices of Stanley harmonic analysers.

6 Summary of Mader-based Harmonic Analysers

In the final section of this article gives an (incomplete) overview of variants of harmonic analyser sets based on Mader's principle. Corresponding references to the source of information and serial numbers are given, if available. Of course, below tables are incomplete, but they are a starting point for collecting information on still existing Mader-Stärzl and Mader-Ott harmonic analysers.

6.1 Overview of Mader-Stärzl Harmonic Analysers

Known serial no.	Manufacturing years	Coefficients to be calculated	No. of gear wheels	No. of intermediate gear wheels	Reference, comments
Without serial no.					Deutsches Museum München, original Mader analyser
S II, No. 2		9	9		Private collection (till 1990 with University of Hannover, Germany, Insitut für Nachrichtentechnik
S II, No. 23	1910 or 1911		10		TU Dresden, Germany, “Historisch Akustisch-Phonetische Sammlung” [Zau2022], [Fis2019]
S II, No. 24	1911	9			[Sci2019, Fis2019]
S II, No. 27	1911		35		TU Dresden, Germany, “Historisch Akustisch-Phonetische Sammlung” [Zau2022]
S II, No. 28		10	10		University Halle, Germany, https://www2.mathematik.uni-halle.de/modellsammlung/
S II, No. 56	ca. 1911				[Lud20??]
S II, No. 76		10	10	0	[GitSie004] (Inventory no: IV/97), one gear wheel missing
S II, No. 80	ca. 1914				[Ack1928] page 376
S II, No. 91		10	10		Collection Zerfowski
S II, No. 92					[Got2015]
S II, No. 153		6	6	0	[Tek2019-1]
S II, No. 161					[Uni2018] Collection University of Stuttgart, Germany
S II, No. 187	ca. 1930				[Tub2019] lists a corresponding device with no details.
			20		[Com2017-2]
S II, No. 190 ⁴	ca. 1930		35		TU Dresden, Germany, “Historisch Akustisch-Phonetische Sammlung” [Zau2022], [Fis2019]

6.2 Overview of Mader-Ott Harmonic Analysers

Without an agreement with Mader, the company Ott started the production of harmonic analysers around the year 1929. The production continued till ca. 1975. Corresponding serial numbers are between 2001 to 2500 (production years 1929-1961) and 69001 to 69100 (manufactured between 1962 and ca. 1972) [Fis2019]. This means that the total amount of produced Mader-Ott harmonic analysers are

⁴Highest series number known for Mader-Stärzl analysers. Series numbers might have been sequentially applied (and therefore mixed) to harmonic analysers and planimeters manufactured by Stärzl [Fis2019].

below 600, especially since multi-carriage analysers use several serial numbers, one for each single carriage.

A portfolio of Mader-Ott analyser variants (including corresponding model numbers and names) is shown in below table. Even though the 8-fold analyser (called *Pezik*) is mentioned in [Ott19??], the 8-fold version with 4 gear sets (Figure 13) is not listed. Additionally the tracer arm extension (called *Pireb*) is listed in [Ott19??].

Device types	Analyser rod for determination of single sine and cosine coefficients of one harmonic:	Single analyser for determination of single sine and cosine coefficients of one harmonic: 1 set of gears 1 planimeter	Double analyser		8-fold analyser for simultaneous determination of sine and cosine coefficients for the same harmonics: 2 sets of gears 8 planimeters
			for determination of single sine and cosine coefficients of two harmonics: 1 set of gears 2 planimeters	for simultaneous determination of sine and cosine coefficients for the same harmonics: 2 sets of gears 2 planimeters	
Gear set for the first 6 harmonics	No. 200 <i>Peran</i>	No. 210 <i>Pesap</i>	No. 210 A <i>Petar</i>	--	
Gear set for the first 9 harmonics	No. 202 <i>Perir</i>	No. 212 <i>Pesem</i>	No. 212 A <i>Petex</i>	--	
Gear set for the uneven harmonics 1-25 and even harmonics 2-18	No. 204 <i>Perut</i>	No. 214 <i>Pesis</i>	No. 214 A <i>Petir</i>	No. 214 B <i>Peweg</i>	
Gear set for the uneven harmonics 1-31 and even harmonics 2-18		No. 216 <i>Pesot</i>	No. 216 A <i>Petov</i>	No. 216 B <i>Pewox</i>	
Gear set for all uneven and even harmonics 1-33		No. 218 <i>Pesur</i>	No. 218 A <i>Petum</i>	No. 218 B <i>Pewur</i>	<i>Pezik</i>
Source of information	[Ott1930]	[Ott19??] (after 1949)			

Figure 19: Overview of Mader-Ott analysers ([Ott1930], [Ott19??]).

Known serial no.	Manufacturing years	Coefficients to be calculated	No. of gear wheels	Intermediate gear wheels	No. of hole plates	Reference, comments
		6	6	0	1	[Pal2013] page 71.
		9	11	2	1	[Ott1931-1], Figure 7.
2034	ca.1930	25	27	5		[Got2015] image 9
		25	27	5	1	[Ott1931-1]
2048	ca.1933	6	6	0	1	[Fli2018]
		19			1 ⁵	Referred in [Nys1937-2]
		21			1	Referred in [Nys1937-2]
		23			1	Referred in [Nys1937-2]
2155 + 2156 + 2157 + 2158	1941	19	4 x 11	4 x 2	4 x 2	Collection Zerfowski (8-fold analyser with 4 carriages, each for 2 planimeters and pantographic extension for graphs up-to 72 cm length)
	1942				1 x 2 1 x 6 + 1 x 6	[Wil1943] page 182, [Mey1944] page 280, with second carriage for 6 planimeters are connected, extendable to 14-fold analyser. Introduced

⁵ A second hole plate on a carriage has been introduced by Ott by 1941 (see [Mey1941] page 220).

IM 2019 Proceedings – Historical Calculating Instruments (updated version)

					optional	in autumn 1942 [Fis2019].
2252			2 x 54			TU Dresden, Germany, “Historisch Akustisch-Phonetische Sammlung” [Zau2022]
2255	1946		2 x 48		2	Pewur 218 B, incl. Stieltjes extension. On 27.07.1946 sold to Dr. Götler, Göttingen. Collection Zerfowski.
2257	1946	1-33	2 x 48		2	[Com2017-1]
2261 + 2263	1946		2 x ?		2	[Pal2013] page 80, with Stieltje supplement (serial no, 2263)
2298						TU Dresden, Germany, “Sammlung Rechentechnik” [Zau2022]
2312			11			[Uni2018] Collection University of Stuttgart, Germany
2370		25	27	5	1	[Gol2016] page 2
2383		25	27	5	2	With 2 planimeters. Ebay Dec. 2010
2412	1958	25	27	5	1	Collection Prof. Anthes
2423		1-33	18	3	1	Collection Zerfowski.
2476						TU Dresden, Germany, “Sammlung Rechentechnik” [Zau2022]
69078	1967					[Tub2019] lists a corresponding device without any further details.

6.3 Overview of Stanley Harmonic Analysers (Mader Type)

Very few is known about existing Stanley harmonic analysers. According to Professor Fischer [Fis2019] at least three devices are with the Science Museum at London.

Known serial no.	Manufacturing years	Coefficients to be calculated	No. of gear wheels	No. of intermediate gear wheels	Reference, comments
					Science Musuem London, Object No. 1978-154.
12	ca. 1952	18	2 x 18	2 x 3	[Tek2019-2]. Model U8103 with double hole plates and 2 planimeters.
32		18	2 x 18	2 x 3	[Otn2008]. Model No. 3 with double hole plates, including 2 planimeters. Offered at ebay August 2020.
33		18	2 x 18	2 x 3	Model No. U8103 with double hole plates. Former with company Shell, now with private collector.

Any additional information on and pictures of corresponding harmonic analysers are highly appretiated, please contact the author via email Detlef@Zerfowski.com

7 Bibliography⁶

[Ack1928] Ackerl, Franz: **Untersuchung über die Genauigkeit des harmonischen Analysators von Dr. O. MADER**, Zeitschrift für Instrumentenkunde, Vol. 48, No. 8, August 1928, pages 375-380.

[Bae1937-1] Baer, Hans: **Genauigkeitsuntersuchungen am Polarplanimeter**, Zeitschrift für Instrumentenkunde, Vol. 57, No. 5, May 1937, pages 177-189. Note: This article and [Bae1937-2] are the dissertation of Mr. Baer.

[Bae1937-2] Baer, Hans: **Genauigkeitsuntersuchungen am harmonischen Analysator Mader-Ott**, Zeitschrift für Instrumentenkunde, Vol. 57, No. 6, June 1937, pages 225-235. Note: This article and [Bae1937-1] are the dissertation of Mr. Baer.

[Boh1931] Bohnstedt-Zörbig, Herbert: **Klanganalytische Untersuchungen an Orgelpfeifen und -mensuren**, Zeitschrift für Instrumentenbau, Vol. 52, No. 2, 15th October 1931.

[Boi1823] Bouilly, Jules: **Portraits et Histoire des Hommes Utiles, Collection de Cinquante Portraits**, Societe Montyon et Franklin, 1839-1840. Portrait of Joseph Fourier painted ca. 1823. <http://web.mit.edu/2.51/www/fourier.jpg>

[Com2017-1] **Computer History Mueum: Harmonic Analyser**, Mountain View, California. Catalog Number 102756991. Shows a Mader-Ott harmonic analyser serial number 2257, dated 1947. The wooden box of size. 88 x 58 x 8 cm contains 2 sets of 48 gear wheels. <https://www.computerhistory.org/collections/catalog/102756991>

[Com2017-2] **Computer Museum University of Amsterdam: Mechanical harmonic analyzer**, Catalog Number 01.40. Shows a Mader harmonic analyser in a box with 20 gear wheels. <https://ub.fnwi.uva.nl/computermuseum/harmonanal.html>

[deM2019] de Man, Andries, Mader-Ott Harmonic Analyser. Interactive animation of the usage of an analyser. Part of electronic version of the Proceedings of the IM2019. <http://www.rekeninstrumenten.nl/im2019/maderott.html>

[Deu2019] **Deutsche Bundesbank: Kaufkraftäquivalente historischer Beträge in deutschen Währungen**. Note: Conversion of historical currency values. www.bundesbank.de/resource/blob/615162/a52b231886b66bdaaf90f26fa12cb335/mL/kaufkraftaequivalente-historischer-betraege-in-deutschen-waehrungen-data.pdf

[Fin1898] Finsterwalder, S.: **Harmonische Analyse mittels des Polarplanimeters**, Zeitschrift für Mathematik und Physik, 1898, Vol. 43, pag 85-92. <https://archive.org/details/zeitschriftfrma14runggooq/page/n93>

[Fis2016] Fischer, Joachim: **Das Jahr 1934 ...**, Dynamical Systems, Number Theory and Applications: A Festschrift in Honor of Armin Leutbecher's 80th Birthday, World Scientific Publishing Co. Ptc. Ltd., 2016, pages 1-19. <https://books.google.de/books?id=bMzACwAAQBAJ>

[Fis2019] Fischer, Joachim: Personal communication with Detlef Zerfowski.

[Fli2018] **Flints Auction: A Harmonic Analyser & Universal Planimeter**, Lot 172, Auction on 26th-27th April 2018, Lot 172, Mader-Ott Analyser serial no. 2148 <https://www.flintsauctions.com/lot/a-harmonic-analyser-universal-planimeter/>

[Fou1822] Fourier, Jean Baptiste Joseph: **Théorie analytique de la chaleur**, Paris, 1822. <https://archive.org/details/thorieanalytiqu00fourgoog/>

⁶Note: All internet links referred to have been accessed and available on 6th July 2019.

[Fre1878] Freeman, Alexander: The Theory of Heat. Edited for the Syndics of University Press, Cambridge, 1878. Translation of [Four1822] <https://archive.org/stream/analyticaltheor01fourgoog>

[GitSie2004] Siebinger, Karl and Gitschthaler, Daniel: Die Historische Sammlung der Fakultät für Physik Universität Wien, Teil 1, Ehemaliges II. Physikalisches Institut: Mechanik, 2004, Wien, page 75. <https://services.phaidra.univie.ac.at/api/object/o:63099/diss/Content/get>

[Gol2016] Gollnick, Martin: Funktionsprinzip des Harmonischen Analysators, TU Freiberg, 2016. Note: Describes a harmonic analyser Mader-Ott. http://www.mathe.tu-freiberg.de/hebisch/cafe/Analysator_Gollnick.pdf

[Got2015] Universität Göttingen: Model collection University Göttingen, 2015, showing the Mader analyser S II serial number 92 and a Mader-Ott analyser box with 27 gear wheels for calculating 25 Fourier coefficients. <http://modellsammlung.uni-goettingen.de/index.php?lang=en&r=0&sr=0&m=556>

[HerZer2002] Zerfowski, Detlef and Herden, Susanne: Geodätisches Rechnen. Eine analoge Rechenmaschine im Büro: das Planimeter, Historische Bürowelt, 2002, No. 63, pages 17-19.

[Hof2022] Hoffmann, Rüdiger: Historische Objekte der Sprachakustik. Katalog der historischen akustisch-phonetischen Sammlung (HAPS) der Technischen Universität Dresden. Zweiter Teil. Dresden: TUDpress, 2022 (Studientexte zur Sprachkommunikation, Band 100).

[Kir1950] Kirkby, S.: The Stanley Harmonic Analyser, W. F. Stanley & Co., Limited, New Eltham, London, ca. 1950, 20 pages.

[Koe19??] Koehler, Gerhard: Harmonische Analysator Mader-Ott Gebrauchsanweisung, Company Ott, Kempten, No. M Ad. 341 III. 2062. 12 pages. Note: Newer version of [Ott1931-1]. Mentions intensive usage of analysers at the "Institut für Praktische Mathematik", Professor Dr. A. Walther, at the University of Darmstadt, Germany

[Lud20??] Ludwig-Maximilians-Universität München: Harmonischer Analysator im Kasten (Integriermaschine), Historische Sammlung des Departments für Physik der Ludwig-Maximilians-Universität München. Shows images of Mader harmonic analyser with serial number S II No. 56, dated ca. 1910. https://homepages.physik.uni-muenchen.de/Juergen.Giersch/HistorischeSammlung/sammlung_test/16_Mathematische_Instrumente/1900X_Harmonischer_Analysator_01_051/medien.html

[Mad1909] Mader, Otto: Ein einfacher harmonischer Analysator mit beliebiger Basis, Elektrotechnische Zeitschrift, Vol. 30, No. 36, 1909, pages 847-849. https://ub.fnwi.uva.nl/computermuseum/pdfs/analyzer_pri.pdf

[Mad1912] Mader, Otto: Ein einfacher harmonischer Analysator mit beliebiger Basis und der Mikro-Indikator, December 1912. Note: 2 pages. Talk given at the Karlsruher Bezirksverein Deutscher Ingenieure on December 16, 1912.

[Mey1938] Meyer zur Capellen, Walther: Berichte: Über den Gebrauch des harmonischen Analysators Mader-Ott, Zeitschrift für Instrumentenkunde, Vol. 58, No. 8, August 1938, pages 339.

[Mey1941] Meyer zur Capellen, Walther: Mathematische Instrumente, Akademische Verlagsgesellschaft Becker & Erler Kom.-Ges., Leipzig, 1941.

[Mey1944] Meyer zur Capellen, Walther: **Mathematische Instrumente**, Akademische Verlagsgesellschaft Becker & Erler Kom.-Ges., Leipzig, 1944, 2nd extended edition.

[Nys1934] Nyström, E. J.: **Planimetrische Auswertung von Stieltjesintegralen**, Zeitschrift angew. Math. Mech., 1934, Vol. 14, pages 276-279.

[Nys1936] Nyström, E. J.: **Ein Instrument zur Auswertung von Stieltjes-Integralen**, Societas Scientiarum Fennica. Commentationes Physico-Mathematicae, 1936, Vol. IX. 4.

[Nys1937] Nyström, E. J.: **Über den Gebrauch des harmonischen Analysators Mader-Ott**, Societas Scientiarum Fennica. Commentationes Physico-Mathematicae, 1937, Vol. IX. 14. http://modellsammlung.uni-goettingen.de/data/Texts/M5/517-524_ueber_den_Gebrauch_des_harmonischen_Analysators_Mader-Ott_Nystroem_1937.pdf

[Orl1906] Orlich, Ernst Max: **Aufnahme und Analyse von Wechselstromkurven**, Vieweg & Sohn, Braunschweig, Elektrotechnik in Einzeldarstellungen, Vol. 7, 1906. Note: 117 pages. Describes harmonic analysers by Henrici and Coradi, Sharp, Yule and Le Conte, Wiechert and Sommerfeld, Michelson and Stratton, Terada.

[Ott1931-1] Ott, A.: **Der harmonische Analysator Mader-Ott**, Mathematisches Institut A. Ott, Kempten, No. M Ad. 341 2054/4, February 1931. Note: 20 pages. See also [Koe19??] and the French version [Ott1931-2]. http://modellsammlung.uni-goettingen.de/data/Texts/M5/357-374_Der_harmonische_Analysator_von_Mader-Ott_Ott.pdf

[Ott1931-2] Ott, A.: **L'Analyseur Harmonique Mader-Ott**, Institut pour l'Étude et la Construction d'Instruments de Mathématiques, Kempten, Bavière, Brochure Af. 341, ca. 1931.

[Ott1958] Ott, A.: **Mathematische Präzisions-Instrumente Preisliste J5**, 2. Februar 1952, Kempten, Bayern. Bem.: 6 seitige Preisliste, u.a. für Harmonische Analysatoren.

[Ott1930] Ott, A.: **Liste 301**, Section "Harmonischer Analysator Mader-Ott", 1930, Firma A. Ott, Kempten, Bayern, pages 19-20.

[Ott19??] Ott, A.: **Harmonischer Analysator Mader-Ott**, Firma A. Ott, Kempten, Bayern, Brochure MLd 477, II, 0,5717. Note: 2 pages advertisement. Contains a table of Mader-Ott analyser models.

[Otn2008] Otnes, Robert K.: **Notes on Mechanical Fourier analyzers**, Journal of the Oughtred Society, Vol. 17, No. 1, 2008, pages 33-41. http://www.oughtred.org/jos/articles/V17.1_OtnesPaper.pdf

[Pal2013] Palm, Michael: **Historische Integratoren der Firma A. Ott - Anschauliche Darstellung der Funktionsweise und Animation**, Prüfungsstelle Darmstadt des Landesschulamtes, 2013, WS 2013/2014. <http://www.integrator-online.de/PDF/Historische%20Integratoren.pdf>. YouTube video showing how to operate a harmonic analyser: <https://www.youtube.com/watch?v=nM-UqRQbce4>

[Sci2019] Science Museum Group: **Harmonic analyser, Mader's form, in fitted case**, Science Museum Group Collection Online, London. Shows a Mader analyser dated 1911. <https://collection.sciencemuseum.org.uk/objects/co60186>

[Sta19??-1] Stanley Co.: Harmonic Analysers for the analysis of complex periodic curves, W. F. Stanley & Co., Limited, New Eltham, London. Note: 6 pages advertisement for Stanley's Harmonic (Mader Type) Analysers U8101, U8102 and U8103.

[Sta19??-2] Stanley Co.: Harmonic Analysers, W. F. Stanley & Co., Limited, New Eltham, London. Note: 6 pages advertisement for Stanley's Harmonic (Mader Type) Analysers U8101, U8102 and U8103. Note: Very similar to [Sta19??-1] but with much lower prices for the analysers.

[Sta19??-3] Gebrüder Stärzl: Gebrauchsanweisung zum Harmonischen Analysator nach Dr. ing. O. Mader, 19??. Note: Refers to article [Mad1909]. https://ub.fnwi.uva.nl/computermuseum/pdfs/analyzer_pri.pdf

[Tek2019-1] Tekniska Museet: Stockholm Sweden. Shows the Mader-Stärzl harmonic analyser S II, No. 153. <https://digitalmuseum.se/021026330667/analysator> (last modification 19th August 2021).

[Tek2019-2] Tekniska Museet: Stockholm Sweden. Shows ta Stanley harmonic analyser. <https://digitalmuseum.org/021026361373/harmonisk-analysator> (last modification 1st June 2021).

[Tho1881] Thomson, William (later Lord Kelvin): The Tide Gauge, Tidal Harmonic Analyser, and Tide Predictor, Proceedings of the Institution of Civil Engineers, Vol. 65, Session 1880-81, Paper No. 1778, pages 2-25, 1881. <https://doi.org/10.1680/imotp.1881.22262>

[Tub2019] TU Berlin, Institut Mathematik, Mathematische Fachbibliothek: Die Sammlung mathematischer Maschinen und Instrumente des Instituts für Mathematik. Lists a Mader-Stärzl and a Mader-Ott harmonic analysers, but without mentioning their serial numbers. https://www.math.tu-berlin.de/mfb/besondere_bestaende/mathematische_instrumente/ (last modification 28th May 2019)

[Uni2018] University of Stuttgart, Faculty 8, Mathematics and Physics, Collection of Mathematical Instruments. 2018. Shows a Stärzl analyser, a Mader-Ott harmonic analyser as well as an extremely rare Stieltjes integral extension. <https://www.f08.uni-stuttgart.de/mathematik/sammlungen/mathematische-instrumente/> (viewed 4th June 2020)

[Vie1951] Vietoris, Leopold: Zum Gebrauch des harmonischen Analysators von Mader-Ott, Zeitschrift für angewandte Mathematik und Mechanik, Vol. 31, 1951, pages 179-181.

[Wag1942] Wagemann, H.; Der erweiterte harmonische Analysator nach Mader=Ott und seine Verwendung, Meteorologische Zeitschrift, Viewe & Sohn, Braunschweig, 1942, Vol. 52, No. 4, pages 134-137. Note: Describes the usage of the 8-fold Mader-Ott harmonic analyser in meteorology.

[Wil1943] Willers, Friedrich Adolf: Mathematische Instrumente, R. Oldenbourg Verlag, München, Berlin, 1943. Note: 272 pages, 196 figures.

[Wil1951] Willers, Friedrich Adolf: Mathematische Maschinen und Instrumente, Akademie Verlag, Berlin, 1951. Note: 318 pages, 251 figures. Contains a description how to perform a Fourier analysis with planimeters.

[Yul1895] Yule, George Udney: On a Simple Form of Harmonic Analyser, Philosophical Magazine and Journal of Science, 1895, Vol. 39, pages 367-374.
<https://ia800302.us.archive.org/27/items/londonedinburgh5391895lon/londonedinburgh5391895lon.pdf>

[Zau2022] Zaun, Jörg: TU Dresden, Germany. Personal communication (14th November 2022) with Detlef Zerfowski.

[Zer2012] Zerfowski, Detlef: Unser weltweites Wissen über mechanische Rechenmaschinen, Rechenschieber und andere Rechenhilfsmittel. Der Versuch einer umfassenden Übersicht des Wissens aus Vergangenheit und Gegenwart. Our World-wide Knowledge on Calculating Machines, Slide Rules and Calculating Tools. An Approach for a Comprehensive Overview of the Knowledge from Past until Present, self published (available with the author), Bangalore, India, 2012. Note: Bibliography and access to corresponding online database with more than 170 references to harmonic analysers.
<https://www.zerfowski.com/BibQuery/book.php>

8 Acknowledgements

I would like to thank Professor Fischer for his very valuable corrections and additional information for this article. Additionally I would like thank Mrs. Dinsler from the company Ott, who provided me information material on Ott harmonic analysers.

9 Epilog – Additional Photos

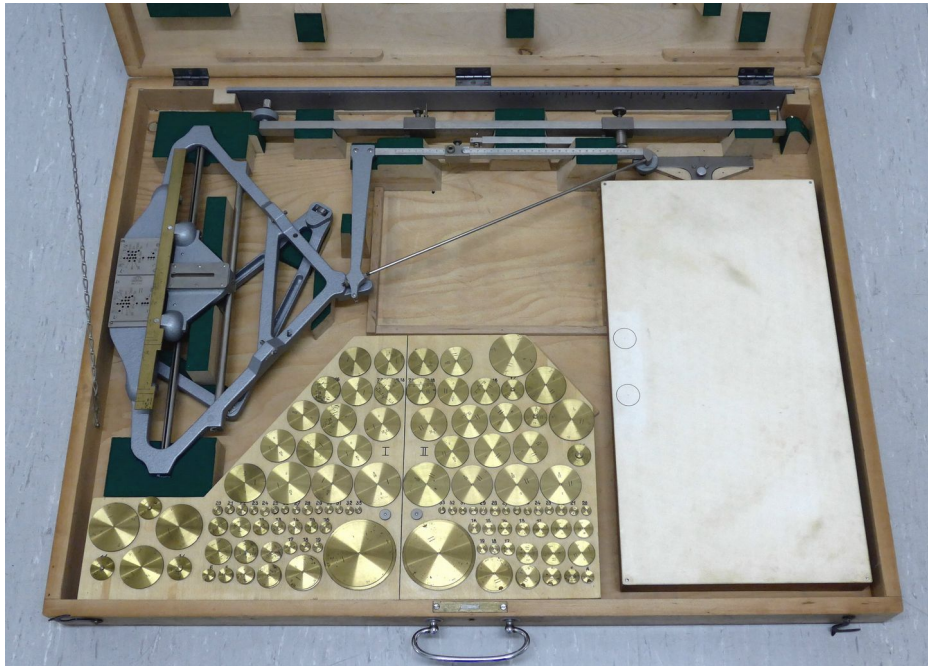

Figure 20: Source: [Hof2022]. Courtesy Rüdiger Hoffmann.



Figure 21: Ott Harmonic Analyser Pewur 218 B Serial Number 2255 including Stieltjes integral extension. Collection Zerfowski.



Figure 22: Stieltjes-Integral Aufsatz (Quelle: TU Dresden <https://sammlungen.tu-dresden.de/Details/Index/2138>, abgerufen 19.03.2023).



**MATHEMATISCHE
PRÄZISIONS-INSTRUMENTE**

PREISLISTE J 5

Blatt 3

Gültig ab 15.2.58

Harmonische Analysatoren Mader-OTT (Liste MLd 477, Ad 341)

Einfach-Analysatoren

mit 1 Rädersatz und 1 Planimeter :

DM

Nr. 210 PESAP	1642.—
Nr. 212 PESEM	1926.—
Nr. 214 PESIS	2674.—
Nr. 216 PESOT	3118.—
Nr. 218 PESUR	4184.—

Doppel-Analysatoren

mit 1 Rädersatz und 2 Planimetern :

Nr. 210 A PETAR	2016.—
Nr. 212 A PETEX	2364.—
Nr. 214 A PETIR	3410.—
Nr. 216 A PETOV	3852.—
Nr. 218 A PETUM	4918.—

Doppel-Analysatoren

mit 2 Rädersatz und 2 Planimetern :

Nr. 214 B PEWEG	4316.—
Nr. 216 B PEWOX	5160.—
Nr. 218 B PEWUR	7292.—

Erweiterungszusätze:

1. Fahrlupe an Stelle des Fahrstiftes	150.—
2. Fahrarmverlängerung für Basislängen bis zu 720 mm PIREB	
a) mit Fahrstift	422.—
b) Ausführung für Verwendung mit Fahrlupe	660.—
3. Anhängewagen mit 6 Räderkästen, 6 Planimetern und 3 Plattformen PIROD	3680.—
4. Ergänzungseinrichtung zum Gebrauch des Analysators als Stieltjesplanimeter PIRIL	2004.—

Achtfach-Analysator PEZIK 11394.—

OTT-Stieltjesplanimeter PIRUF

(Liste MLd 477, Dd 369) **3038.—**

Figure 23: Excerpt from price list [Ott1958]. The Ott 8-fold analyzer PEZIK had been sold for 11394,- DM which would be 31292 Euro equivalent in 2022.

10 Update Revision

Date	Revision description
20.11.2023	Section 6.3: Serial number 33 (Stanley Harmonic Analyser) added.
20.03.2023	Section 6.2: Serial number 2255 added (Figure 21). Section 7, and references in text: [Ott19??-1] changed to [Ott1930] and [Ott19??-2] changed to [Ott19??]. Section 7+9: Price list added ([Ott1958] and Figure 23). Section 9: Additional photo of Stieltjes integral extension (Figure 22).
12.12.2022	Section 7: Reference [Hof2022] added. Section 9 added: Additional photos of Mader-Ott Analyser Serial Number 2252.
14.11.2022	Section 6.1: Additional Mader-Stärzl Analysers added. Section 6.2: Additional Mader-Ott Analysers added. References: Source [Zau2022] added.
05.03.2022	Section 6.2: Serial number 2370 of Mader-Ott Analyser shown [Gol2016]. Source: TU Freiberg.
08.02.2022	Additional Stärzl analysers Serial No. 28 and No. 91 added.
19.08.2021	Stärzl analyser of Tekniska Museet [Tek2019-1]: Earlier the webpage showed a wrong serial number 135. The museum confirmed the correct serial number 153 and corrected the internet page.
04.06.2020	Stärzl analyser Serial No. 161, Mader-Ott analyzer 2312 and Stieltjes integral extension found on internet page of the University of Stuttgart [Uni2018].
14.08.2020	Additional Mader-Ott analyzer 2423 found and added
17.08.2020	Table in Section 6.3: - Based on recent ebay offer Serial number 32 added. - Serial No 12 and corresponding reference [Tek2019-2] added.
30.04.2020	Additional Mader-Stärzel analyser Serial No. 2 (private collection)